

ENG

CRANES

Design, engineering, manufacture

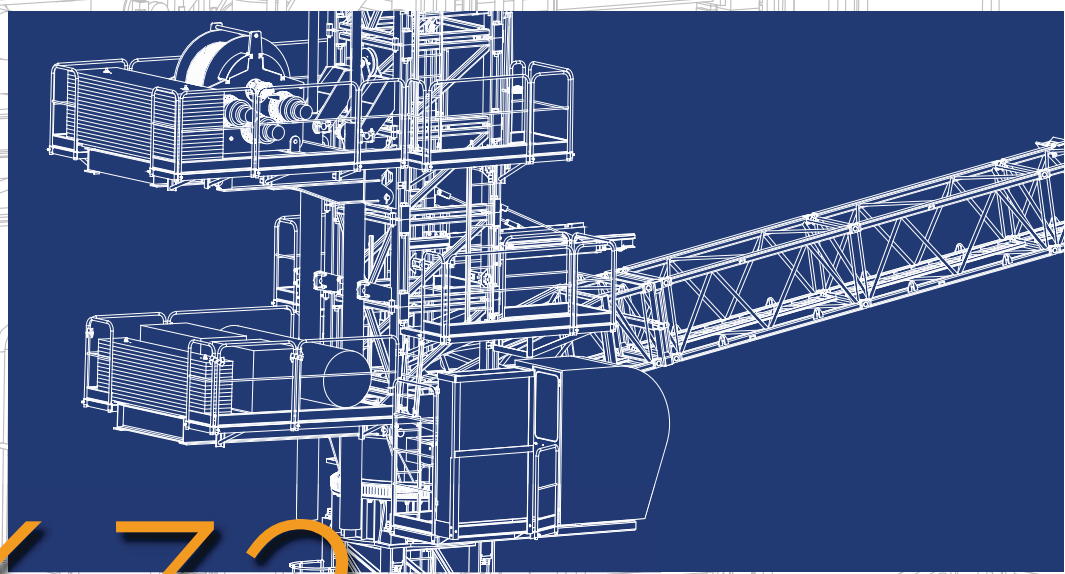

EDK 32

3t

2017

CE EN14439-C25

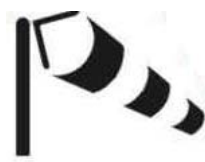
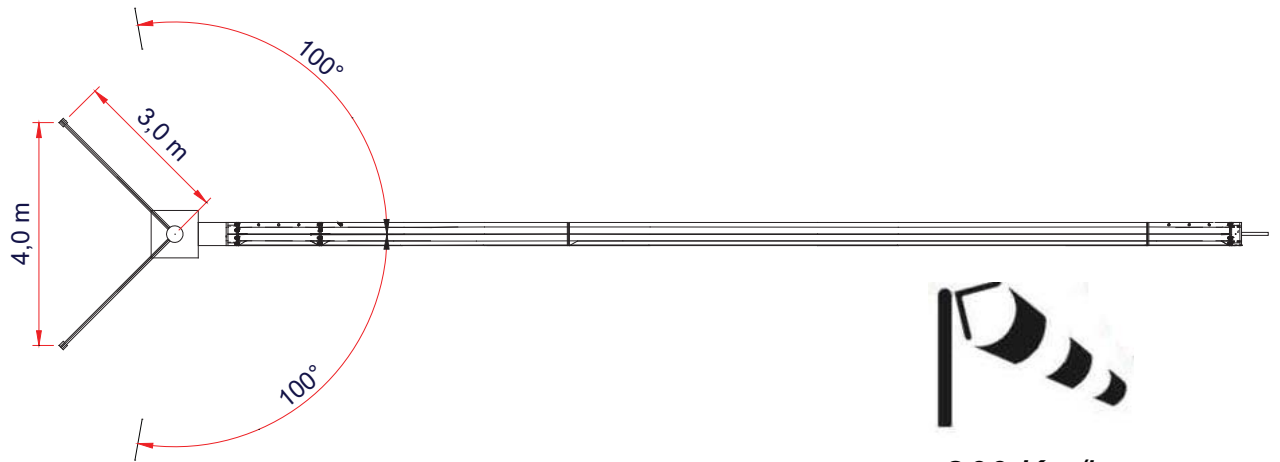
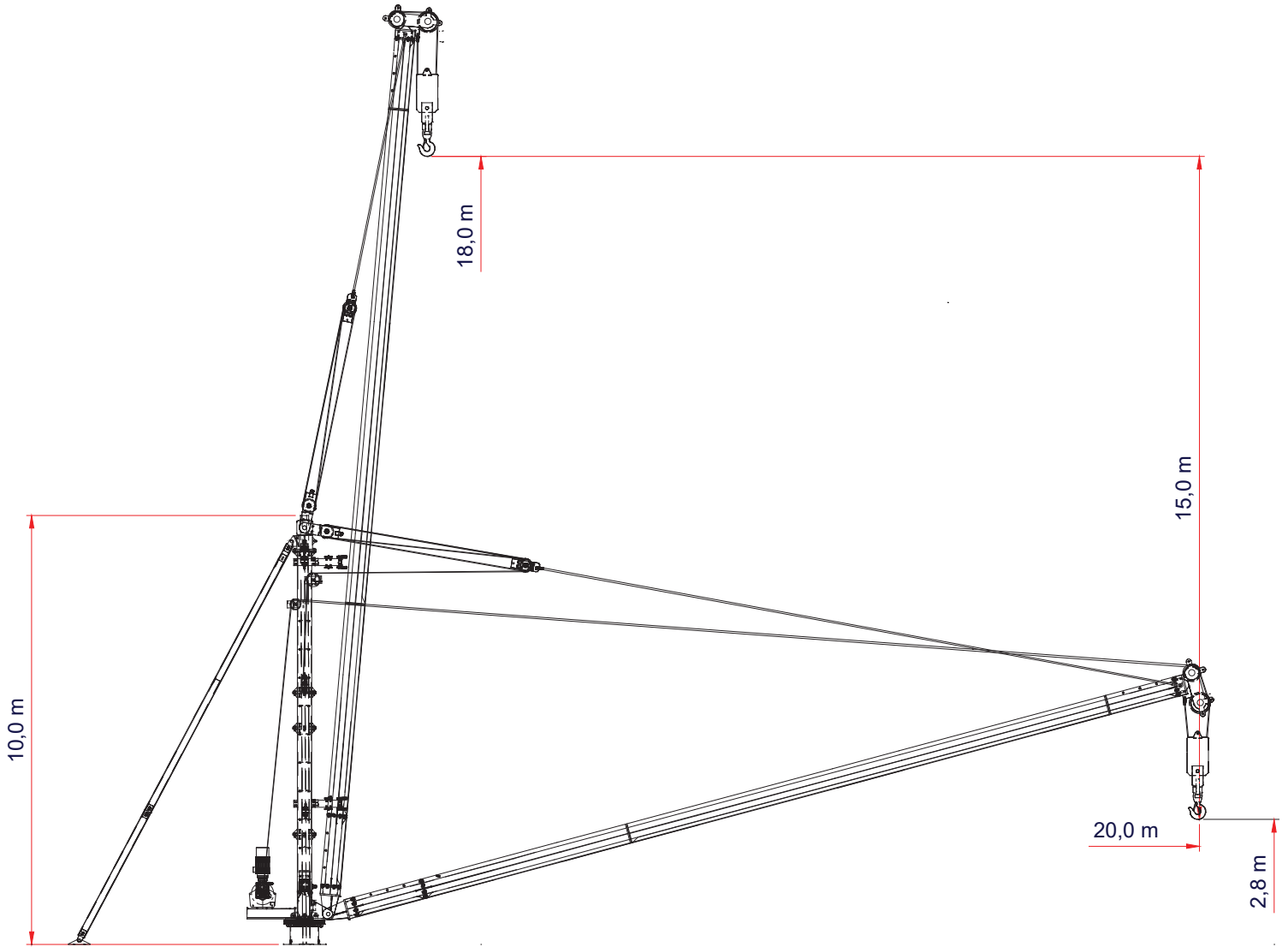

200 Km/h

		Speed - Velocità - Vitesse - Geschwindigkeit	Power - Potenza - Puissance - Leistung
Slewing Rotazione Orientation Schwenken		0 → 0,40 r.p.m.	1x4 kW
Luffing Impennamento Impennage Einziehwerk		1,2 → 2,5 min	7,5 kW

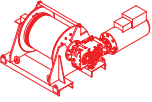
Type Tipo Type Type	Power - Potenza Puissance - Leistung		Rope - Fune Cable - Seil	
	hp - CV PS - ch	kW	m	
 DHW355BR-145050	7,5	5,5	479	
Layer - Strati Couches - Lagen	N. 6			
Step - Marcia Vitesse - Gang	kg	m/min	kg	m/min
1	1500	3,0	3000	2,0
2	1500	10,0	3000	5,0
3	1500	17,0	3000	8,0
4	970	27,0	2010	13,0
5	760	34,0	1600	17,0
6	480	40,0	1050	20,0
Maximum height - Massima altezza - Hauteur maximale - Maximale Höhe	● 473 m		●● 234 m	

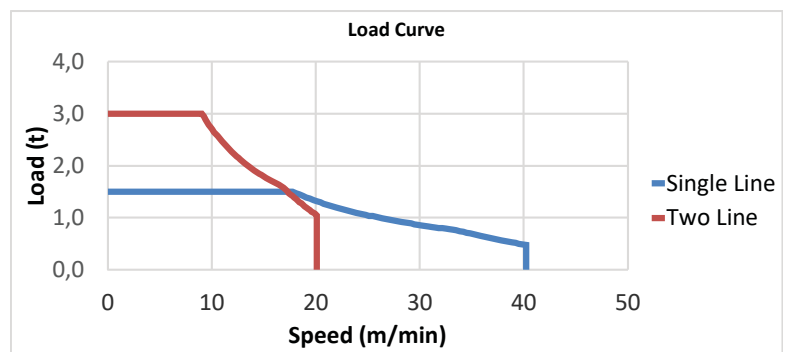

TOTAL INSTALLED POWER FORZA MOTRICE TOTALE PUISSANCE TOTALE DES MOTEURS GESAMT-MOTORENLEISTUNG	5,5 kW (7,5 hp) 16 kVA - 400/480 V - 50/60 Hz ±5% ±2%
---	---

Braccio - Jib Flèche - Ausleger (m)	20	18	16	14,5	12,5	10,5	9
		11,0	11,0	11,0	11,0	11,0	10,5
Raggio - Radius Portée - Ausladung (m)							
2,0	3,00	3,00	3,00	3,00	3,00	3,00	3,00
2,5	3,00	3,00	3,00	3,00	3,00	3,00	3,00
3,0	3,00	3,00	3,00	3,00	3,00	3,00	3,00
3,5	3,00	3,00	3,00	3,00	3,00	3,00	3,00
4,0	3,00	3,00	3,00	3,00	3,00	3,00	3,00
4,5	3,00	3,00	3,00	3,00	3,00	3,00	3,00
5,0	3,00	3,00	3,00	3,00	3,00	3,00	3,00
5,5	3,00	3,00	3,00	3,00	3,00	3,00	3,00
6,0	3,00	3,00	3,00	3,00	3,00	3,00	3,00
6,5	3,00	3,00	3,00	3,00	3,00	3,00	3,00
7,0	3,00	3,00	3,00	3,00	3,00	3,00	3,00
7,5	3,00	3,00	3,00	3,00	3,00	3,00	3,00
8,0	3,00	3,00	3,00	3,00	3,00	3,00	3,00
8,5	3,00	3,00	3,00	3,00	3,00	3,00	3,00
9,0	3,00	3,00	3,00	3,00	3,00	3,00	3,00
9,5	3,00	3,00	3,00	3,00	3,00	3,00	
10,0	3,00	3,00	3,00	3,00	3,00	3,00	
10,5	3,00	3,00	3,00	3,00	3,00	3,00	
11,0	3,00	3,00	3,00	3,00	3,00		
11,5	2,82	2,88	3,00	2,87	2,85		
12,0	2,64	2,70	2,82	2,69	2,67		
12,5	2,48	2,53	2,65	2,53	2,60		
13,0	2,33	2,38	2,50	2,38			
13,5	2,19	2,25	2,35	2,24			
14,0	2,06	2,12	2,22	2,11			
14,5	1,95	2,00	2,10	2,10			
15,0	1,84	1,89	1,99				
15,5	1,73	1,79	1,88				
16,0	1,64	1,69	1,80				
16,5	1,55	1,60					
17,0	1,46	1,51					
17,5	1,38	1,43					
18,0	1,31	1,40					
18,5	1,24						
19,0	1,17						
19,5	1,10						
20,0	1,10						

Braccio - Jib Flèche - Ausleger (m)	20	18	16	14,5	12,5	10,5	9
		15,5	16,0	16,0	14,5	12,5	11,0
Raggio - Radius Portée - Ausladung (m)	 1,5 t						
2,0	1,50	1,50	1,50	1,50	1,50	1,50	1,50
2,5	1,50	1,50	1,50	1,50	1,50	1,50	1,50
3,0	1,50	1,50	1,50	1,50	1,50	1,50	1,50
3,5	1,50	1,50	1,50	1,50	1,50	1,50	1,50
4,0	1,50	1,50	1,50	1,50	1,50	1,50	1,50
4,5	1,50	1,50	1,50	1,50	1,50	1,50	1,50
5,0	1,50	1,50	1,50	1,50	1,50	1,50	1,50
5,5	1,50	1,50	1,50	1,50	1,50	1,50	1,50
6,0	1,50	1,50	1,50	1,50	1,50	1,50	1,50
6,5	1,50	1,50	1,50	1,50	1,50	1,50	1,50
7,0	1,50	1,50	1,50	1,50	1,50	1,50	1,50
7,5	1,50	1,50	1,50	1,50	1,50	1,50	1,50
8,0	1,50	1,50	1,50	1,50	1,50	1,50	1,50
8,5	1,50	1,50	1,50	1,50	1,50	1,50	1,50
9,0	1,50	1,50	1,50	1,50	1,50	1,50	1,50
9,5	1,50	1,50	1,50	1,50	1,50	1,50	
10,0	1,50	1,50	1,50	1,50	1,50	1,50	
10,5	1,50	1,50	1,50	1,50	1,50	1,50	
11,0	1,50	1,50	1,50	1,50	1,50		
11,5	1,50	1,50	1,50	1,50	1,50		
12,0	1,50	1,50	1,50	1,50	1,50		
12,5	1,50	1,50	1,50	1,50	1,50		
13,0	1,50	1,50	1,50	1,50			
13,5	1,50	1,50	1,50	1,50			
14,0	1,50	1,50	1,50	1,50			
14,5	1,50	1,50	1,50	1,50			
15,0	1,50	1,50	1,50				
15,5	1,50	1,50	1,50				
16,0	1,50	1,50	1,50				
16,5	1,50	1,50					
17,0	1,47	1,50					
17,5	1,39	1,46					
18,0	1,32	1,40					
18,5	1,25						
19,0	1,19						
19,5	1,12						
20,0	1,10						

ENG

CRANES

Design, engineering, manufacture

ENG CRANES SRL

Via Limido 1/E
42024 Castelnuovo di Sotto - RE
Italy

Info + 39 0522 149518
Fax + 39 0522 1495601

commerciale@engcranes.com
www.engcranes.com

Edition 2017 - Rev 01

Specifications and data not binding subject to modification without notice.
Dati illustrativi non impegnativi con riserva di modifica senza preavviso.
Données techniques seulement indicatives modifications réservées sans préavis.
Angaben und Beschreib unverbindlich andreungen vorbehalten ohne weitere mitteilung.